



TECHNICAL SPECIFICATIONS

BETA ENERJİ VE TEKNOLOJİ ANONİM ŞİRKETİ
Acıdereosb Mah. Çanakkale Cd. No: 11
Sarıçam / ADANA - Tel: 444 2 1 01
Faks: 0 322 394 42 53 E-mail: info@betatransformer.com
Yüreğir V.D. 059 115 6239

BSA.24.225

CAST RESIN TRANSFORMER

Elc. Eng. Mehmet DÜVERLİOĞLU

28.02.2024

ELECTRICAL DATA

Standards:	IEC 60076-11	
Service:	Distribution	
Rated Power	2500/3500	kVA
Primary Side:		
Rated Voltage	10	kV
Voltage Tappings	$\pm 2 \times 2.5\%$	
Rated Current	144,34/202,07	A
Connection	Delta	
Secondary Side:		
Rated Voltage	0,4	kV
Rated Current	3608,44/5051,81	A
Connection	Star + N	
No Load Loss (Ecodesign Tier-1)	3100	W
Load Loss at 120°C (Ecodesign Tier-1)	19000	W
Short Circuit Impedance at 120°C (\pm IEC tolerances)	6	%
Sound Pressure Level	71	dB
Partially Discharge Level	≤ 10	pC
Number of Phase	3	
Frequency	50	Hz
Vector Group	Dyn11	
Insulating Class (Primary/Secondary)	F/F	
Maximum Temperature Rise of Windings	100	K
Cooling Method	AN-AF	
Conductor Material (Primary/Secondary)	AL/AL	
Insulation Level of Primary Side	12/28/75	kV
Insulation Level of Secondary Side	1,1/3/-	kV
Classes:		
Climatic	C2	
Environmental	E2	
Fire	F1	
Altitude	1000	m
Location	Indoor	
Enclosure		
Protection Class	IP00	
Material	-	
Thickness of Steel Sheet	-	
Thickness of Coating	-	
Colour	-	
Enclosure Weight	-	

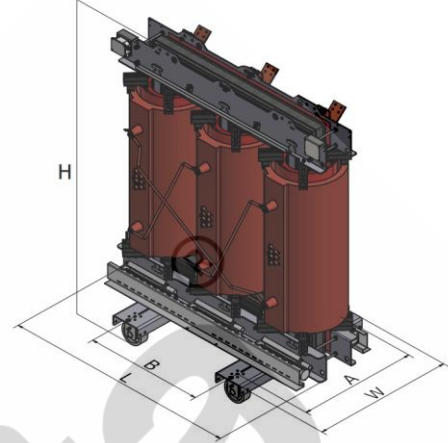

DIMENSIONS

Length	L	1845	mm
Width	W	1270	mm
Height	H	2375	mm
Wheels Center	AxB	1070x1070	mm
Wheels Diameter		200	mm
Transformer Weight		5020	kg
Total Weight		5020	kg

*Dimensions and weight are $\pm 10\%$ toleranced.

INCLUDED ACCESSORIES

- PT100 temperature sensors
- PT100 distribution box IP55
- Temperature Controller Relay
- Wheels (Adjustable in two ways)
- Rating Plate
- Earthing terminal
- Eyebolts for horizontal moving
- Lifting Lugs
- Use and Maintenance Manual
- Routine Test Report
- Cooling Fan

Technical Remarks: Tolerance and tests according to IEC 60076 (if not otherwise indicated)

Dimensions and weight are approximate and will be confirmed after PO

Warranty referred at nominal power rating and nominal voltage ratio (the highest in case of double primary voltages)

Sound pressure level referred at 1000 mm with AN and +3 dB tolerance

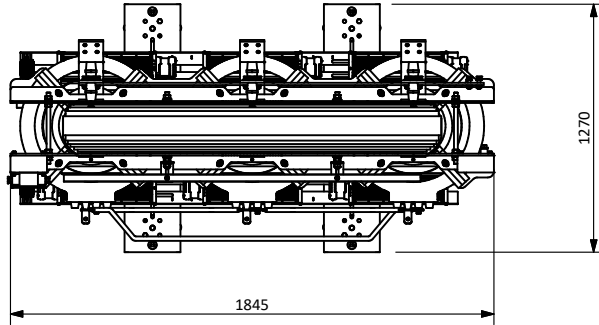
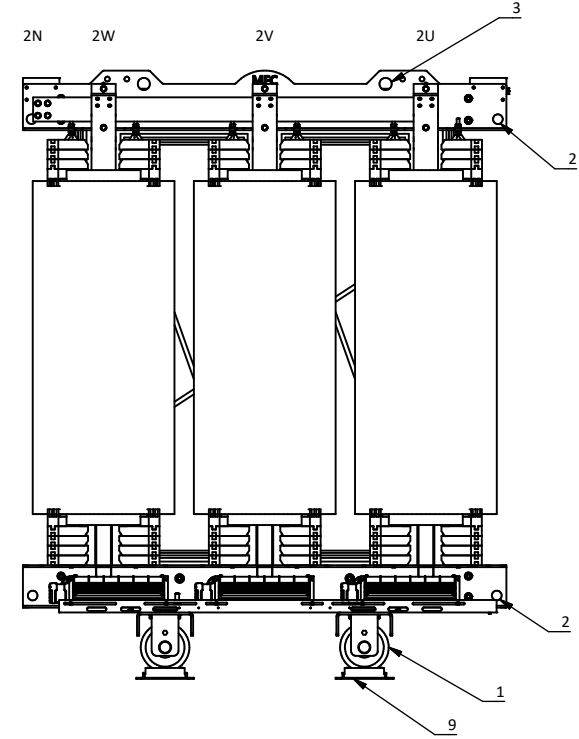
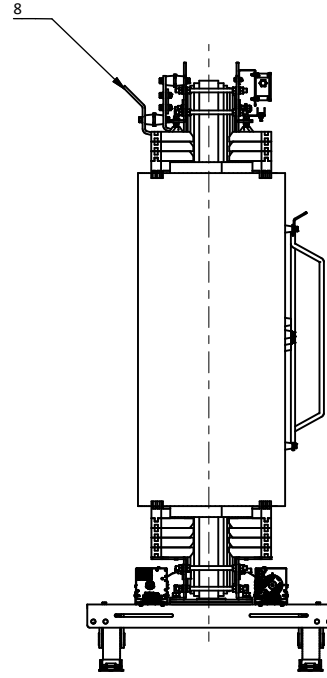
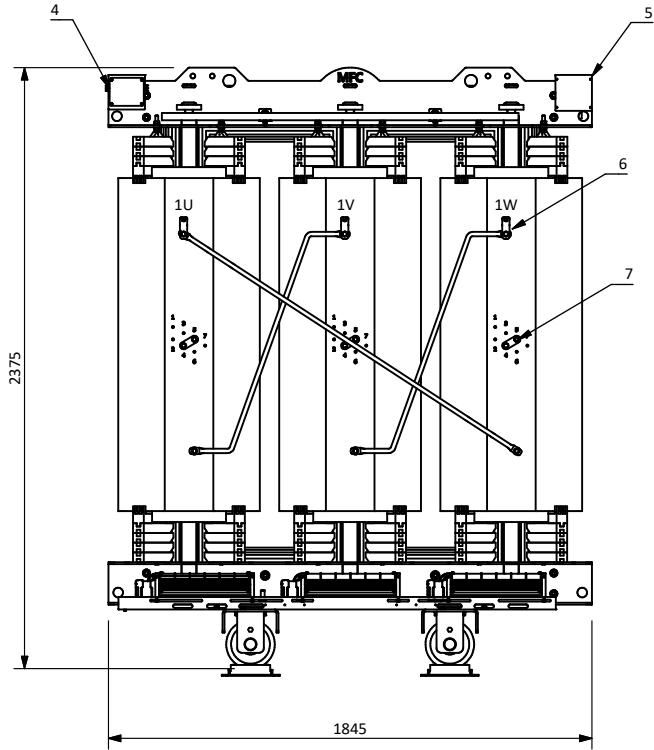

- 1- WHEEL
- 2- PULLING LUG D=40
- 3- LIFTING LUG D=50
- 4- PT100 TERMINAL BOX
- 5- NAMEPLATE
- 6- HV TERMINAL
- 7- HV TAP LINK
- 8- LV TERMINAL
- 9- ANTI VIBRATION PAD

TOTAL MASS = 5020 kg.

00	29.02.2024	ALPER BILICI	ALPER BILICI	First Issue
Revision	Date	Prepared	Checked	Description
Project :				Title
2500 kVA 10/0.4 kV Dyn11				Dimensional Drawing
All dimensions are in mm. Dimensions are toleranced ± 10 Scale: A3				Drawing No
				Page
				1
				Total Page
				1

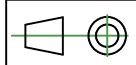

Page
1

Total Page
1